

| Part #                  | Application  | Parts List  |
|-------------------------|--|---|
| 75015, 87015<br>& 85015 | 02-08 DODGE RAM 1500<br>03-08 DODGE RAM 2500, 3500 | Gas Door Assembly<br>4ea-M6x20mm Flat Cap Screws<br>2ea-Plastic Spacers |
| 75014, 87014<br>& 85014 | 94-01 DODGE RAM 1500<br>94-04 DAKOTA               | 4ea-6mm Hex Nuts<br>4ea-Flat Washers<br>4ea-Tooth Lock Washers          |

### Tools Needed:

4mm Allen wrench – T30 Torx Driver – 10mm open-end wrench – Phillips & Flat head screwdrivers.

- 1) Remove parts from the package and check against parts list- Note: Some parts may be preinstalled & require removal.
- 2) Read through instruction list and make sure you understand before proceeding.
- 3) Open gas door and remove the (2) factory gas door bolts and detach the factory gas door and bracket. Also remove the (2) rubber door stops (twist and pull) as shown in fig 1.
- 4) Prior to vehicle installation, check the latch and door assembly, and make sure the door cover and outer ring are flush in the closed position. If needed, adjust the latch with the two Phillips screws.
- 5) Place the new gas door in position and align the two attachment holes to the left side of the gas door with the original factory installation holes. Insert two M6 flat cap screws and snug with lock washers and hex nuts. Do not tighten bolts, as spacers will be inserted on the right side.
- 6) Insert the two nylon spacers on the right side, between the gas door outer ring and the vehicle sheet metal, then align the spacers with the now open rubber door stop holes and the two available holes on the right side of the outer ring. Insert two M6 flat cap screws and snug with lock washers and hex nuts.
- 7) Check overall alignment and tighten all bolts. Test unit operation.

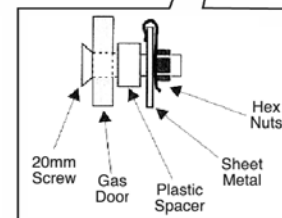
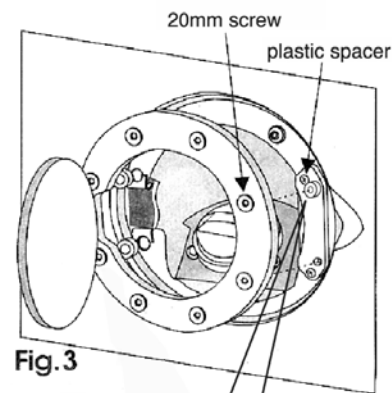
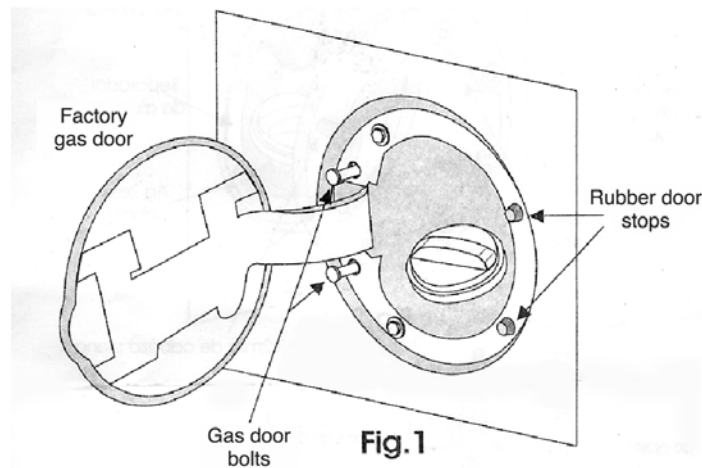

This product is guaranteed to be free of defects in materials and workmanship for a period of 12 months  
Rampage Products 9225 Stellar Ct. #C, Corona Ca., 92883  
Made In China